

Basics of Electrochemical Impedance Spectroscopy

This document presents an introduction to Electrochemical Impedance Spectroscopy (EIS) theory and has been kept as free from mathematics and electrical theory as is possible. If you still find the material presented here difficult to understand, don't stop reading. You will get useful information from this chapter even if you don't follow all of the discussions.

Four major topics are covered in this Application Note.

- AC Circuit Theory and Representation of Complex Impedance Values
- Physical Electrochemistry and Circuit Elements
- Common Equivalent Circuit Models
- Extracting Model Parameters from Impedance Data

No prior knowledge of electrical circuit theory or electrochemistry is assumed. Each topic starts out at a quite elementary level. Each topic proceeds from this simple beginning to cover more advanced material.

AC Circuit Theory and Representation of Complex Impedance Values

Impedance definition: concept of complex impedance

Almost everyone knows about the concept of electrical resistance. It is the ability of a circuit element to resist the flow of electrical current. Ohm's law (Equation 1) defines resistance in terms of the ratio between voltage E and current I .

$$R \equiv \frac{E}{I} \quad (1)$$

While this is a well known relationship, its use is limited to only one circuit element -- the ideal resistor. An ideal resistor has several simplifying properties:

- It follows Ohm's Law at all current and voltage levels.
- Its resistance value is independent of frequency.
- AC current and voltage signals through a resistor are in phase with each other.

The real world contains circuit elements that exhibit much more complex behavior. These elements force us to abandon the simple concept of resistance. In its place we use impedance, which is a more general circuit

parameter. Like resistance, impedance is a measure of the ability of a circuit to resist the flow of electrical current. Unlike resistance, impedance is not limited by the simplifying properties listed above.

Electrochemical impedance is usually measured by applying an AC potential to an electrochemical cell and measuring the current through the cell. Assume that we apply a sinusoidal potential excitation. The response to this potential is an AC current signal. This current signal can be analyzed as a sum of sinusoidal functions (a Fourier series).

Electrochemical Impedance is normally measured using a small excitation signal. This is done so that the cell's response is pseudo-linear. Linearity is described in more detail in the following section. In a linear (or pseudo-linear) system, the current response to a sinusoidal potential will be a sinusoid at the same frequency but shifted in phase. See Figure 1.

Figure 1
Sinusoidal Current Response in a Linear System

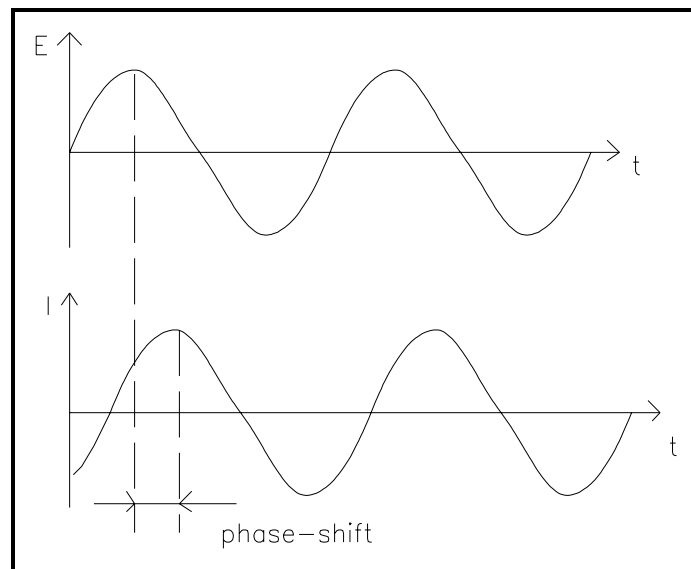

The excitation signal, expressed as a function of time, has the form

$$E_t = E_0 \sin(\omega t) \quad (2)$$

E_t is the potential at time t , E_0 is the amplitude of the signal, and ω is the radial frequency. The relationship between radial frequency ω (expressed in radians/second) and frequency f (expressed in hertz) is:

$$\omega = 2 \pi f \quad (3)$$

In a linear system, the response signal, I_t , is shifted in phase (ϕ) and has a different amplitude, I_0 .

$$I_t = I_0 \sin (\omega t + \phi) \quad (4)$$

An expression analogous to Ohm's Law allows us to calculate the impedance of the system as:

$$Z = \frac{E_t}{I_t} = \frac{E_0 \sin(\omega t)}{I_0 \sin(\omega t + \phi)} = Z_0 \frac{\sin(\omega t)}{\sin(\omega t + \phi)} \quad (5)$$

The impedance is therefore expressed in terms of a magnitude, Z_0 , and a phase shift, ϕ .

If we plot the applied sinusoidal signal $E(t)$ on the X-axis of a graph and the sinusoidal response signal $I(t)$ on the Y-axis, the result is an oval. See Figure 2. This oval is known as a "Lissajous Figure". Analysis of Lissajous Figures on oscilloscope screens was the accepted method of impedance measurement prior to the availability of modern EIS instrumentation.

Figure 2
Origin of Lissajous Figure

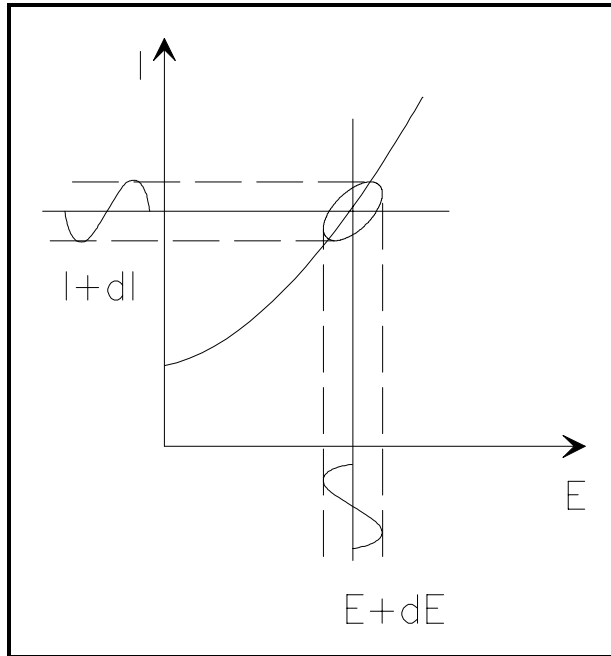

With Eulers relationship,

$$\exp(j\phi) = \cos\phi + j\sin\phi \quad (6)$$

it is possible to express the impedance as a complex function. The potential is described as,

$$E_t = E_0 \exp(j\omega t) \quad (7)$$

and the current response as,

$$I_t = I_0 \exp(j\omega t - \phi) \quad (8)$$

The impedance is then represented as a complex number,

$$Z(\omega) = \frac{E}{I} = Z_0 \exp(j\phi) = Z_0 (\cos\phi + j\sin\phi) \quad (9)$$

Data Presentation

Look at Equation 9 in the previous section. The expression for $Z(\omega)$ is composed of a real and an imaginary part. If the real part is plotted on the X-axis and the imaginary part is plotted on the Y-axis of a chart, we get a "Nyquist Plot". See Figure 3. Notice that in this plot the Y-axis is negative and that each point on the Nyquist Plot is the impedance at one frequency. Figure 3 has been annotated to show that low frequency data are on the right side of the plot and higher frequencies are on the left.

On the Nyquist Plot the impedance can be represented as a vector (arrow) of length $|Z|$. The angle between this vector and the X-axis, commonly called the "phase angle", is ϕ ($=\arg Z$).

Nyquist Plots have one major shortcoming. When you look at any data point on the plot, you cannot tell what frequency was used to record that point.

Figure 3
Nyquist Plot with Impedance Vector

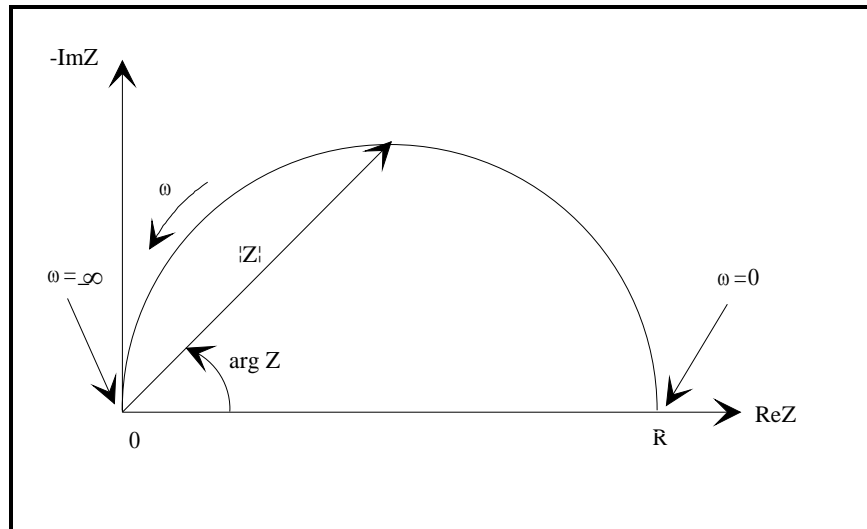

The Nyquist Plot in Figure 3 results from the electrical circuit of Figure 4. The semicircle is characteristic of a single "time constant". Electrochemical Impedance plots often contain several semicircles. Often only a portion of a semicircle is seen.

Figure 4
Simple Equivalent Circuit with One Time Constant

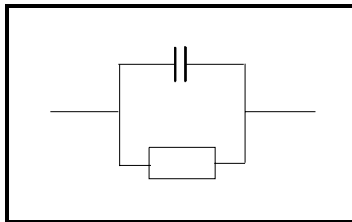

Another popular presentation method is the Bode Plot. The impedance is plotted with log frequency on the X-axis and both the absolute values of the impedance ($|Z|=Z_0$) and the phase-shift on the Y-axis.

The Bode Plot for the electric circuit of Figure 4 is shown in Figure 5. Unlike the Nyquist Plot, the Bode Plot does show frequency information.

Figure 5
Bode Plot with One Time Constant

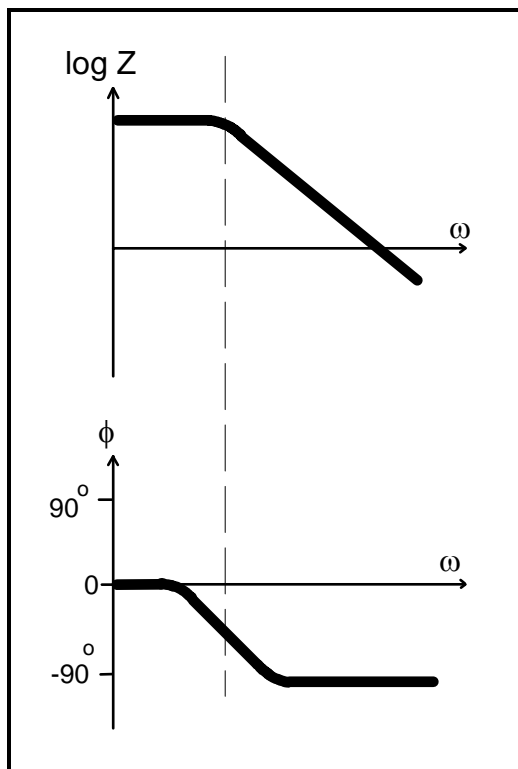

Linearity of Electrochemistry Systems

Electrical circuit theory distinguishes between linear and non-linear systems (circuits). Impedance analysis of linear circuits is much easier than analysis of non-linear ones.

The following definition of a linear system is taken from *Signals and Systems* by Oppenheim and Willsky:

A linear system ... is one that possesses the important property of superposition: If the input consists of the weighted sum of several signals, then the output is simply the superposition, that is, the weighted sum, of the responses of the system to each of the signals. Mathematically, let $y_1(t)$ be the response of a continuous time system to $x_1(t)$ and let $y_2(t)$ be the output corresponding to the input $x_2(t)$. Then the system is linear if:

- 1) The response to $x_1(t) + x_2(t)$ is $y_1(t) + y_2(t)$
- 2) The response to $ax_1(t)$ is $ay_1(t)$...

For a potentiostated electrochemical cell, the input is the potential and the output is the current. Electrochemical cells are not linear! Doubling the voltage will not necessarily double the current.

However, Figure 6 shows how electrochemical systems can be pseudo-linear. If you look at a small enough portion of a cell's current versus voltage curve, it appears to be linear.

In normal EIS practice, a small (1 to 10 mV) AC signal is applied to the cell. With such a small potential signal, the system is pseudo-linear. We don't see the cell's large nonlinear response to the DC potential because we only measure the cell current at the excitation frequency.

Figure 6
Current versus Voltage Curve Showing Pseudo-Linearity

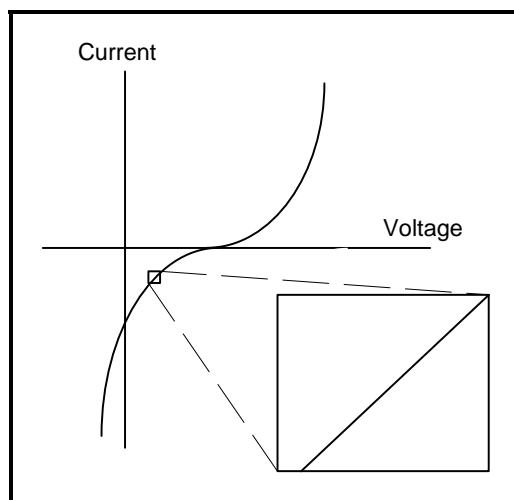

If the system is non-linear, the current response will contain harmonics of the excitation frequency. A harmonic is a frequency equal to an integer multiplied by the fundamental frequency. For example, the "second harmonic" is a frequency equal to two times the fundamental frequency.

Some researchers have made use of this phenomenon. Linear systems should not generate harmonics, so the presence or absence of significant harmonic response allows one to determine the systems linearity. Other researchers have intentionally used larger amplitude excitation potentials. They use the harmonic response to estimate the curvature in the cell's current voltage curve.

Steady State Systems

Measuring an EIS spectrum takes time (often many hours). The system being measured must be at a steady state throughout the time required to measure the EIS spectrum. A common cause of problems in EIS measurements and their analysis is drift in the system being measured.

In practice a steady state can be difficult to achieve. The cell can change through adsorption of solution impurities, growth of an oxide layer, build up of reaction products in solution, coating degradation, temperature changes, to list just a few factors.

Standard EIS analysis tools may give you wildly inaccurate results on a system that is not at steady state.

Time and Frequency Domains and Transforms

Signal processing theory refers to data representation domains. The same data can be represented in different domains. In EIS, we use two of these domains, the time domain and the frequency domain.

In the time domain, signals are represented as signal amplitude versus time. Figure 7 demonstrates this for a signal consisting of two superimposed sine waves.

Figure 7
Two Sine Waves in the Time Domain

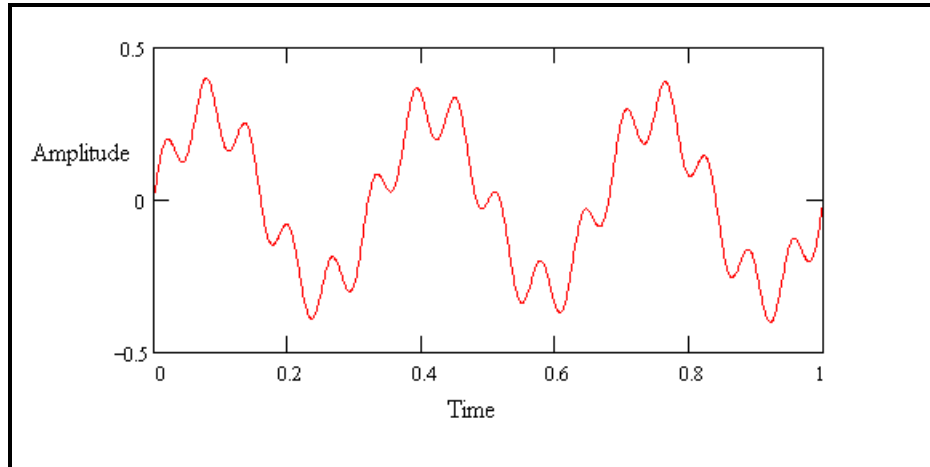
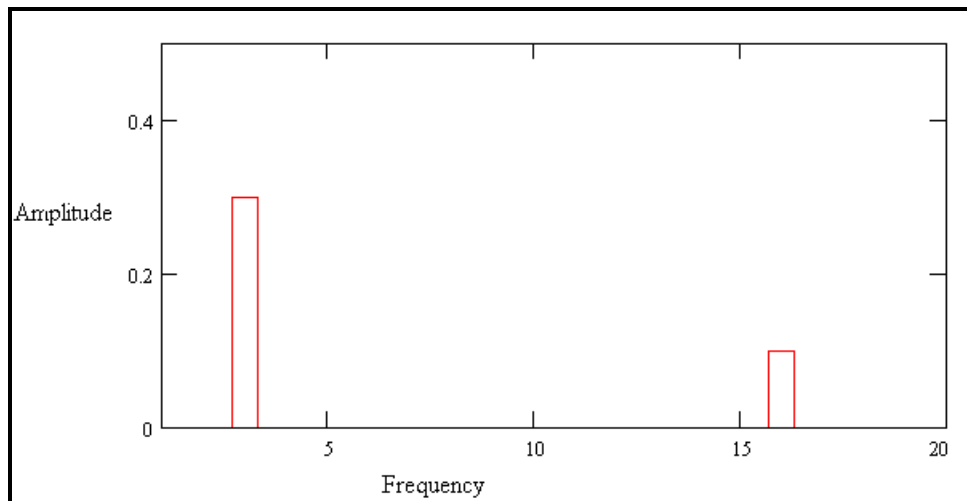

Figure 8 shows the same data in the frequency domain. The data is plotted as amplitude versus frequency.

Figure 8
Two Sine Waves in the Frequency Domain



You use a transform to switch between the domains. The Fourier Transform takes time domain data and generates the equivalent frequency domain data. The common term, FFT, refers to a fast, computerized

implementation of the Fourier transform. The inverse Fourier transform changes frequency domain data into time domain data.

In modern EIS systems, lower frequency data are usually measured in the time domain. The controlling computer applies a digital approximation to a sine wave to the cell by means of a digital-to-analog converter. The current response is measured using an analog-to-digital converter. The FFT is used to convert the current signal into the frequency domain.

Details of these transforms are beyond the scope of this Application Note.

Electrical Circuit Elements

EIS data is commonly analyzed by fitting it to an equivalent electrical circuit model. Most of the circuit elements in the model are common electrical elements such as resistors, capacitors, and inductors. To be useful, the elements in the model should have a basis in the physical electrochemistry of the system. As an example, most models contain a resistor that models the cell's solution resistance.

Some knowledge of the impedance of the standard circuit components is therefore quite useful. Table 1 lists the common circuit elements, the equation for their current versus voltage relationship, and their impedance.

Table 1
Common Electrical Elements

<u>Component</u>	<u>Current Vs.Voltage</u>	<u>Impedance</u>
resistor	$E = IR$	$Z = R$
inductor	$E = L di/dt$	$Z = j\omega L$
capacitor	$I = C dE/dt$	$Z = 1/j\omega C$

Notice that the impedance of a resistor is independent of frequency and has no imaginary component. With only a real impedance component, the current through a resistor stays in phase with the voltage across the resistor.

The impedance of an inductor increases as frequency increases. Inductors have only an imaginary impedance component. As a result, the current through an inductor is phase-shifted -90 degrees with respect to the voltage.

The impedance versus frequency behavior of a capacitor is opposite to that of an inductor. A capacitor's impedance decreases as the frequency is raised. Capacitors also have only an imaginary impedance component. The current through a capacitor is phase shifted 90 degrees with respect to the voltage.

Serial and Parallel Combinations of Circuit Elements

Very few electrochemical cells can be modeled using a single equivalent circuit element. Instead, EIS models usually consist of a number of elements in a network. Both serial and parallel combinations of elements occur.

Fortunately, there are simple formulas that describe the impedance of circuit elements in both parallel and series combination.

Figure 9
Impedances in Series

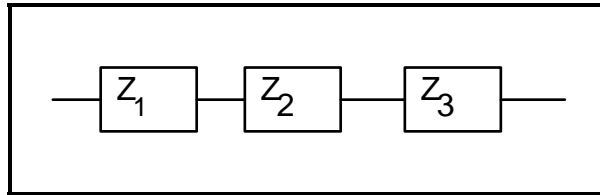

For linear impedance elements in series you calculate the equivalent impedance from:

$$Z_{eq} = Z_1 + Z_2 + Z_3 \quad (10)$$

Figure 10
Impedances in Parallel

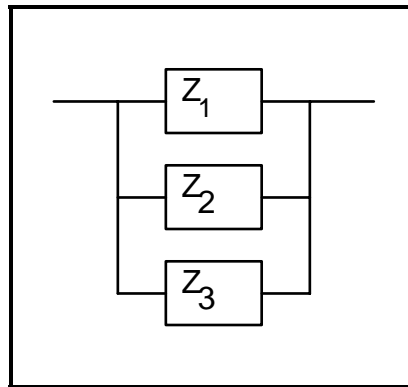

For linear impedance elements in parallel you calculate the equivalent impedance from:

$$\frac{1}{Z_{eq}} = \frac{1}{Z_1} + \frac{1}{Z_2} + \frac{1}{Z_3} \quad (11)$$

We will calculate two examples to illustrate a point about combining circuit elements. Suppose we have a 1Ω and a 4Ω resistor in series. The impedance of a resistor is the same as its resistance (see Table 1). We thus calculate the total impedance as:

$$Z_{eq} = Z_1 + Z_2 = R_1 + R_2 = 1 \Omega + 4 \Omega = 5 \Omega$$

Resistance and Impedance both go up when resistors are combined in series.

Now suppose that we connect two $2 \mu\text{F}$ capacitors in series. The total capacitance of the combined capacitors is $1 \mu\text{F}$.

$$\begin{aligned}
Z_{\text{eq}} &= Z_1 + Z_2 = 1/j\omega C_1 + 1/j\omega C_2 \\
&= 1/j\omega(2e-6) + 1/j\omega(2e-6) \\
&= 1/j\omega(1e-6)
\end{aligned}$$

Impedance goes up, but capacitance goes down when capacitors are connected in series. This is a consequence of the inverse relationship between capacitance and impedance.

Physical Electrochemistry and Equivalent Circuit Elements

Electrolyte resistance

Solution resistance is often a significant factor in the impedance of an electrochemical cell. A modern 3 electrode potentiostat compensates for the solution resistance between the counter and reference electrodes. However, any solution resistance between the reference electrode and the working electrode must be considered when you model your cell.

The resistance of an ionic solution depends on the ionic concentration, type of ions, temperature, and the geometry of the area in which current is carried. In a bounded area with area A and length l carrying a uniform current, the resistance is defined as,

$$R = \rho \frac{l}{A} \quad (12)$$

ρ is the solution resistivity. The reciprocal of ρ (κ) is more commonly used. κ is called the conductivity of the solution and its relationship with solution resistance is:

$$R = \frac{1}{\kappa} \cdot \frac{l}{A} \Rightarrow \kappa = \frac{l}{RA} \quad (13)$$

Standard chemical handbooks will often list κ values for specific solutions. For other solutions, you can calculate κ from specific ion conductances. The unit of κ is the Siemens per meter (S/m). The Siemen is the reciprocal of the ohm, so $1S=1/\text{ohm}$.

Unfortunately, most electrochemical cells do not have uniform current distribution through a definite electrolyte area. The major problem in calculating solution resistance therefore concerns determination of the current flow path and the geometry of the electrolyte that carries the current. A comprehensive discussion of the approaches used to calculate practical resistances from ionic conductances is well beyond the scope of this manual.

Fortunately, you usually don't calculate solution resistance from ionic conductances. Instead, you calculate it when you fit experimental EIS data to a model.

Double layer capacitance

An electrical double layer exists on the interface between an electrode and its surrounding electrolyte. This double layer is formed as ions from the solution "stick on" the electrode surface. The charged electrode is separated from the charged ions. The separation is very small, often on the order of angstroms.

Charges separated by an insulator form a capacitor. On a bare metal immersed in an electrolyte, you can estimate that there will be 20 to 60 μF of capacitance for every 1 cm^2 of electrode area.

The value of the double layer capacitance depends on many variables. Electrode potential, temperature, ionic concentrations, types of ions, oxide layers, electrode roughness, impurity adsorption, etc. are all factors.

Polarization Resistance

Whenever the potential of an electrode is forced away from its value at open-circuit, that is referred to as "polarizing" the electrode. When an electrode is polarized, it can cause current to flow through electrochemical reactions that occur at the electrode surface. The amount of current is controlled by the kinetics of the reactions and the diffusion of reactants both towards and away from the electrode.

In cells where an electrode undergoes uniform corrosion at open circuit, the open circuit potential is controlled by the equilibrium between two different electrochemical reactions. One of the reactions generates cathodic current and the other anodic current. The open circuit potential ends up at the potential where the cathodic and anodic currents are equal. It is referred to as a mixed potential. The value of the current for either of the reactions is known as the corrosion current.

Mixed potential control also occurs in cells where the electrode is not corroding. While this section discusses corrosion reactions, modification of the terminology makes it applicable in non-corrosion cases as well.

When there are two simple, kinetically controlled reactions occurring, the potential of the cell is related to the current by the following equation.

$$I = I_{corr} \left(e^{\frac{2.303(E-E_{oc})}{\beta_a}} - e^{\frac{-2.303(E-E_{oc})}{\beta_c}} \right) \quad (14)$$

where

- I is the measured cell current in amps,
- I_{corr} is the corrosion current in amps,
- E_{oc} is the open circuit potential in volts,
- β_a is the anodic Beta coefficient in volts/decade,
- β_c is the cathodic Beta coefficient in volts/decade.

If we apply a small signal approximation to equation 14, we get the following:

$$I_{corr} = \frac{\beta_a \beta_c}{2.303(\beta_a + \beta_c)} \cdot \left(\frac{1}{R_p} \right) \quad (15)$$

which introduces a new parameter, R_p , the polarization resistance. As you might guess from its name, the polarization resistance behaves like a resistor.

If the Tafel constants are known, you can calculate the I_{corr} from R_p using equation 15. I_{corr} in turn can be used to calculate a corrosion rate.

We will discuss the R_p parameter in more detail when we discuss cell models.

Charge Transfer Resistance

A similar resistance is formed by a single kinetically-controlled electrochemical reaction. In this case we do not have a mixed potential, but rather a single reaction at equilibrium.

Consider a metal substrate in contact with an electrolyte. The metal can electrolytically dissolve into the electrolyte, according to,



or more generally



In the forward reaction in the first equation, electrons enter the metal and metal ions diffuse into the electrolyte. Charge is being transferred.

This charge transfer reaction has a certain speed. The speed depends on the kind of reaction, the temperature, the concentration of the reaction products and the potential.

The general relation between the potential and the current (which is directly related with the amount of electrons and so the charge transfer via Faradays law) is:

$$i = i_0 \left(\frac{C_O}{C_O^*} \exp\left(\frac{\alpha n F \eta}{RT}\right) - \left(\frac{C_R}{C_R^*} \exp\left(\frac{-(1-\alpha)n F \eta}{RT}\right) \right) \right) \quad (18)$$

with,

i_0	= exchange current density
C_O	= concentration of oxidant at the electrode surface
C_O^*	= concentration of oxidant in the bulk
C_R	= concentration of reductant at the electrode surface
η	= overpotential ($E_{\text{app}} - E_{\text{oc}}$)
F	= Faradays constant
T	= temperature
R	= gas constant
α	= reaction order
n	= number of electrons involved

When the concentration in the bulk is the same as at the electrode surface, $C_O = C_O^*$ and $C_R = C_R^*$. This simplifies equation 18 into:

$$i = i_0 \left(\exp\left(\alpha \frac{nF}{RT} \eta\right) - \exp\left(- (1-\alpha) \frac{nF}{RT} \eta\right) \right) \quad (19)$$

This equation is called the Butler-Volmer equation. It is applicable when the polarization depends only on the charge-transfer kinetics. Stirring the solution to minimize the diffusion layer thickness can help minimize concentration polarization.

When the overpotential, η , is very small and the electrochemical system is at equilibrium, the expression for the charge transfer resistance changes to:

$$R_{ct} = \frac{RT}{nFi_0} \quad (20)$$

From this equation the exchange current density can be calculated when R_{ct} is known.

Diffusion

Diffusion also can create an impedance called a Warburg impedance. The impedance depends on the frequency of the potential perturbation. At high frequencies the Warburg impedance is small since diffusing reactants don't have to move very far. At low frequencies the reactants have to diffuse farther, increasing the Warburg-impedance.

The equation for the "infinite" Warburg impedance is:

$$Z_w = \sigma (\omega)^{-1/2} (1 - j) \quad (21)$$

On a Nyquist Plot the Warburg impedance appears as a diagonal line with an slope of 45°. On a Bode Plot, the Warburg impedance exhibits a phase shift of 45°.

In equation 21, σ is the Warburg coefficient defined as:

$$\sigma = \frac{RT}{n^2 F^2 A \sqrt{2}} \left(\frac{1}{C_o^* \sqrt{D_O}} + \frac{1}{C_R^* \sqrt{D_R}} \right) \quad (22)$$

In which,

- ω = radial frequency
- D_O = diffusion coefficient of the oxidant
- D_R = diffusion coefficient of the reductant
- A = surface area of the electrode
- n = number of electrons involved

This form of the Warburg impedance is only valid if the diffusion layer has an infinite thickness. Quite often, however, this is not the case. If the diffusion layer is bounded, the impedance at lower frequencies no longer obeys the equation above. Instead, we get the form:

$$Z_o = \sigma \omega^{-1/2} (1 - j) \tanh\left(\delta \left(\frac{j\omega}{D}\right)^{1/2}\right) \quad (23)$$

with,

- δ = Nernst diffusion layer thickness
- D = some average value of the diffusion coefficients of the diffusing species

This more general equation is called the "finite" Warburg. For high frequencies where $\omega \rightarrow \infty$, or for an infinite thickness of the diffusion layer where $\delta \rightarrow \infty$, $\tanh(\delta \frac{j\omega}{D})^{1/2} \rightarrow 1$ and equation 23 simplifies to the infinite Warburg impedance. Sometimes these equations are written in terms of an admittance parameter, $Y_0 = 1/(\sigma\sqrt{2})$. See Table 3.

Coating capacitance

A capacitor is formed when two conducting plates are separated by a non-conducting media, called the dielectric. The value of the capacitance depends on the size of the plates, the distance between the plates and the properties of the dielectric. The relationship is,

$$C = \frac{\epsilon_0 \epsilon_r A}{d} \quad (24)$$

With,

- ϵ_0 = permittivity of free space (NIST calls it simply the "electric constant")
- ϵ_r = dielectric constant (relative electrical permittivity)
- A = surface of one plate
- d = distances between two plates

Whereas the permittivity of free space is a physical constant, the dielectric constant depends on the material. Table 3 gives you some useful ϵ_r values.

Table 2
Typical Dielectric Constants

Material	ϵ_r
vacuum	1
water	80.1 (20°C)
organic coating	4 - 8

Notice the large difference between the dielectric constant of water and that of an organic coating. The capacitance of a coated substrate changes as it absorbs water. EIS can be used to measure that change.

Constant Phase Element

Capacitors in EIS experiments often do not behave ideally. Instead, they act like a constant phase element as defined below.

The impedance of a capacitor can be expressed as:

$$Z = (1/Y_0)(j\omega)^{-\alpha} \quad (25)$$

where,

$Y_0 = C =$ The capacitance

$\alpha =$ An exponent that equals 1 for a capacitor

For a constant phase element, the exponent α is less than one. The "double layer capacitor" on real cells often behaves like a CPE, not a capacitor. While several theories (surface roughness, "leaky" capacitor, non-uniform current distribution, etc.) have been proposed to account for the non-ideal behavior of the double layer, it is probably best to treat α as an empirical constant with no real physical basis.

Virtual Inductor

The impedance of an electrochemical cell sometimes also appears to be inductive. Some workers have ascribed inductive behavior to the formation of a surface layer, like a passive layer or fouling. Others have claimed that inductive behavior results from errors in the measurement, including potentiostat non-idealities.

Common Equivalent Circuit Models

In the following section we show some common equivalent circuits models. These models can be used to interpret simple EIS data. Many of these models have been included as standard models in the Gamry EIS300 Electrochemical Impedance Spectroscopy Software.

The elements used in the following equivalent circuits are presented in Table 3. Equations for both the admittance and impedance are given for each element.

Table 3
Circuit Elements Used in the Models

<u>Equivalent element</u>	<u>Admittance</u>	<u>Impedance</u>
R	$1/R$	R
C	$j\omega C$	$1/j\omega C$
L	$1/j\omega L$	$j\omega L$
W (infinite Warburg)	$Y_0\sqrt{(j\omega)}$	$1/Y_0\sqrt{(j\omega)}$
O (finite Warburg)	$Y_0\sqrt{(j\omega)}\text{Coth}(B\sqrt{(j\omega)})$	$\text{Tanh}(B\sqrt{(j\omega)})/Y_0\sqrt{(j\omega)}$
Q (CPE)	$Y_0(j\omega)^\alpha$	$1/Y_0(j\omega)^\alpha$

The dependent variables used in these equations are R, C, L, Y_0 , B, and α . The EIS300 uses these as fit parameters.

Purely Capacitive Coating

A metal covered with an undamaged coating generally has a very high impedance. The equivalent circuit for such a situation is in Figure 11.

Figure 11
Purely Capacitive Coating

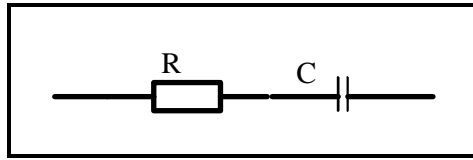

The model includes a resistor (due primarily to the electrolyte) and the coating capacitance in series.

A Nyquist Plot for this model is shown in figure 12. In making this plot, the following values were assigned:

- R = 500 Ω (a bit high but realistic for a poorly conductive solution)
- C = 200 pF (realistic for a 1 cm² sample, a 25 μ m coating, and $\epsilon_r = 6$)
- F_i = 0.1 Hz (lowest frequency is a bit higher than typical)
- F_f = 1 MHz (highest frequency at the EIS300 limit)

Figure 12
Typical Nyquist Plot for an Excellent Coating

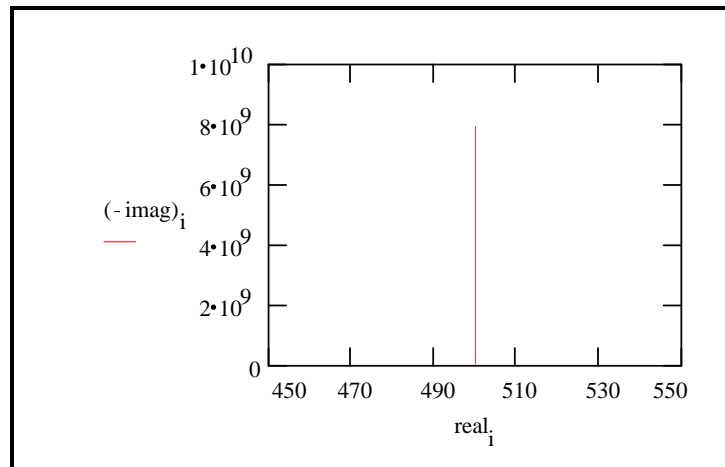

The value of the capacitance cannot be determined from the Nyquist Plot. It can be determined by a curve fit or from an examination of the data points. Notice that the intercept of the curve with the real axis gives an estimate of the solution resistance.

The highest impedance on this graph is close to $10^{10} \Omega$. This is close to or above the limit of measurement capability of most EIS instruments.

The same data are shown in a Bode Plot in Figure 13. Notice that the capacitance can be estimated from the graph but the solution resistance value does not appear on the chart. Even at 100 kHz, the impedance of the coating is higher than the solution resistance.

Figure 13
Typical Bode Plot for an Excellent Coating

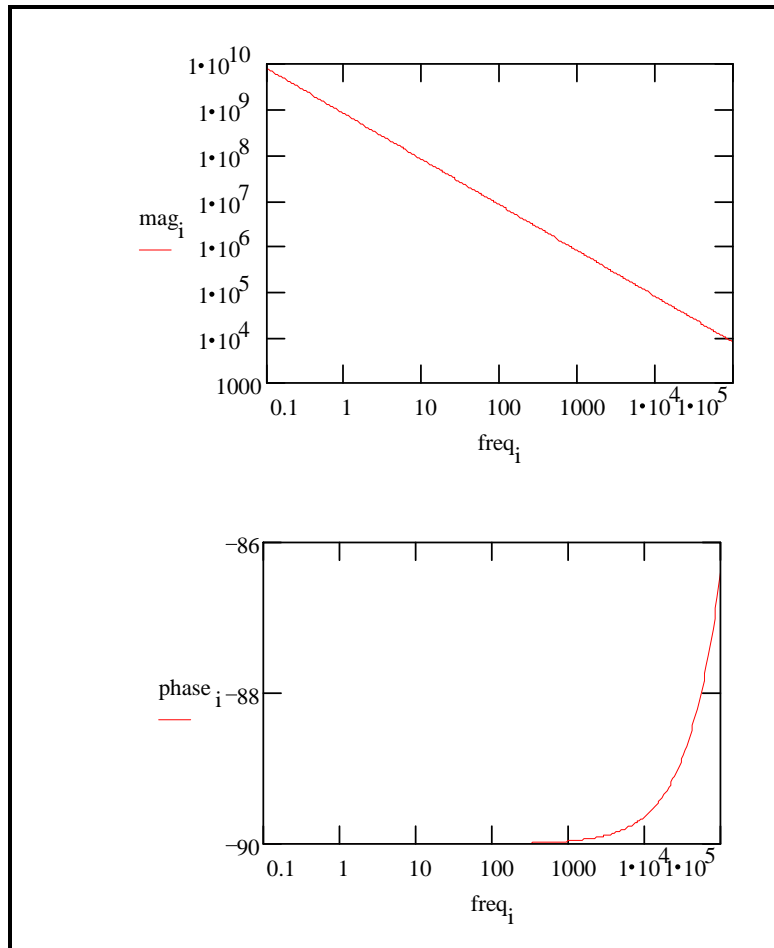

Water uptake into the film is usually a fairly slow process. It can be measured by taking EIS spectra at set time intervals. An increase in the film capacitance can be attributed to water uptake.

Simplified Randles Cell

The Simplified Randles cell is one of most common cell models. It includes a solution resistance, a double layer capacitor and a charge transfer (or polarization resistance). The double layer capacitance is in parallel with the charge transfer resistance. In addition to being a useful model in its own right, the Simplified Randles Cell is the starting point for other more complex models.

The equivalent circuit for a Simplified Randles Cell is shown in Figure 14.

Figure 14
Simplified Randles Cell Schematic Diagram

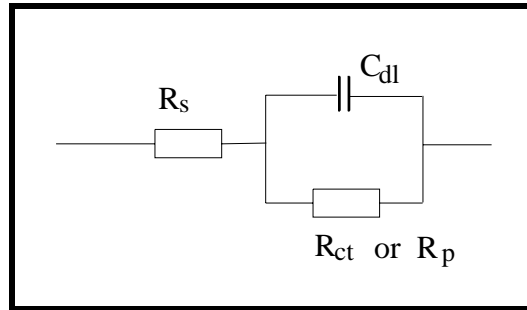
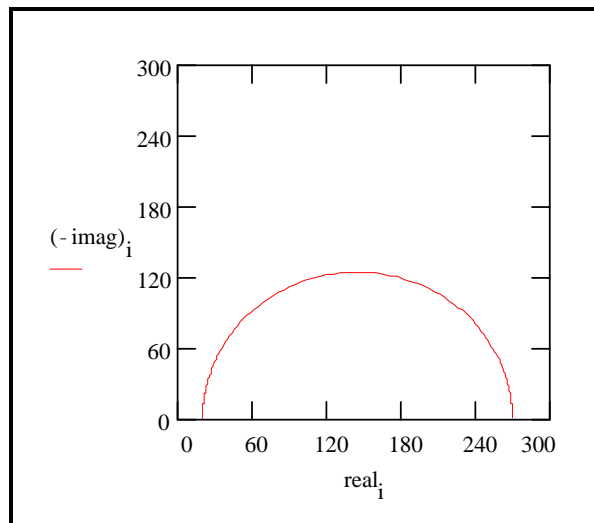

Figure 15 is the Nyquist Plot for a typical Simplified Randles cell. The parameters in this plot were calculated assuming a 1 cm^2 electrode undergoing uniform corrosion at a rate of 1 mm/year . Reasonable assumptions were made for the Tafel coefficients, metal density and equivalent weight. The polarization resistance under these conditions was calculated to be 250Ω . A capacitance of $40 \mu\text{F/cm}^2$ and a solution resistance of 20Ω were also assumed.

Figure 15
Nyquist Plot for 1 mm/year Corrosion Rate



The Nyquist Plot for a Simplified Randles cell is always a semicircle. The solution resistance can be found by reading the real axis value at the high frequency intercept. This is the intercept near the origin of the plot. Remember this plot was generated assuming that $R_s = 20 \Omega$ and $R_p = 250 \Omega$

The real axis value at the other (low frequency) intercept is the sum of the polarization resistance and the solution resistance. The diameter of the semicircle is therefore equal to the polarization resistance (in this case 250Ω).

Figure 16 is the Bode Plot for the same cell.

Figure 16
Bode Plot for 1 mm/year Corrosion Rate

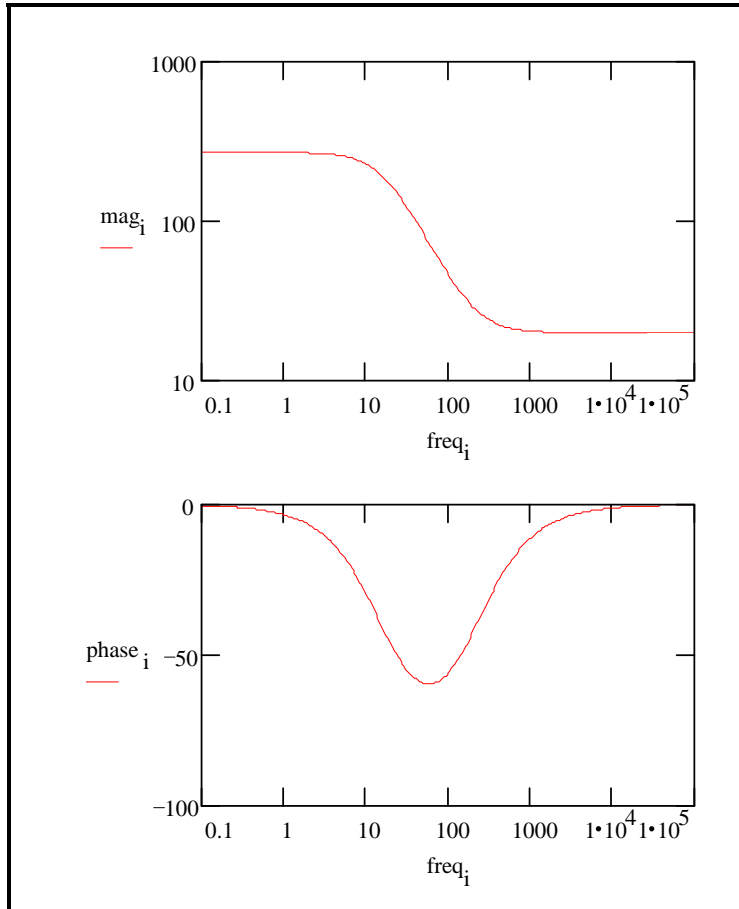

Mixed Kinetic and Diffusion Control

First consider a cell where semi-infinite diffusion is the rate determining step, with a series solution resistance as the only other cell impedance. (See page 13 to refresh your memory.)

A Nyquist Plot for this cell is shown in Figure 17. R_s was assumed to be 20Ω . The Warburg coefficient, σ , is calculated to be about 150 for the diffusion of a species with a bulk concentration of $100 \mu\text{M}$ and a typical diffusion coefficient of $1.6 \times 10^{-5} \text{ cm}^2/\text{s}$. Notice that the Warburg Impedance appears as a straight line with a slope of 45° .

Figure 17
Nyquist Plot for a Warburg Impedance

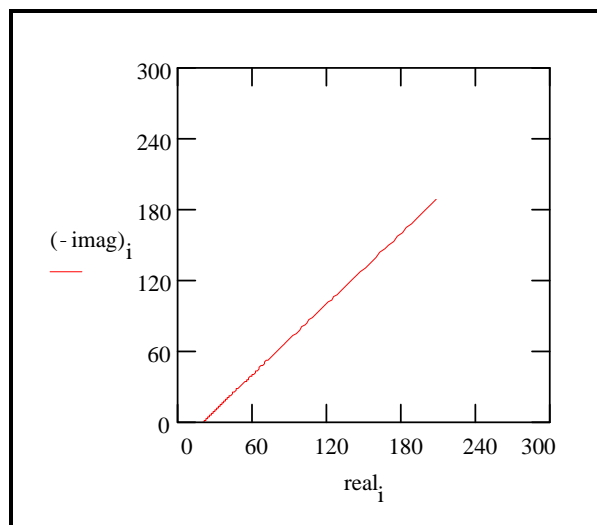

The same data is plotted in the Bode format in Figure 18. The phase angle of a Warburg impedance is 45° .

Figure 18
Bode Plot for a Warburg Impedance

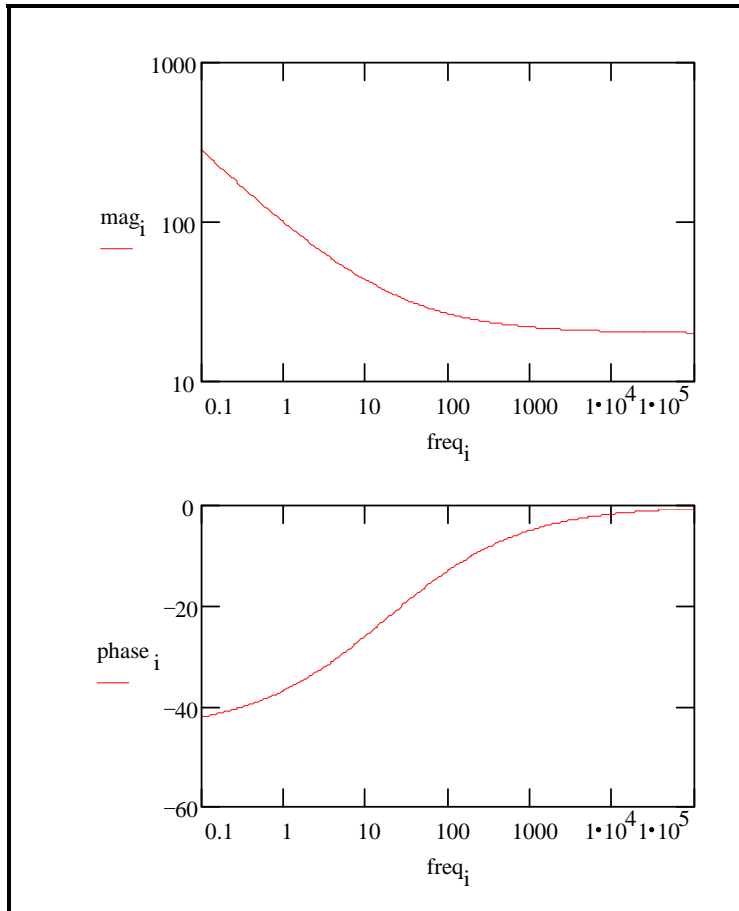

Adding a double layer capacitance and a charge transfer impedance, we get the equivalent circuit in Figure 19. This is the Randles Cell; the name is taken from an article by J.E.B. Randles in the Discussions of the Faraday Society in 1947. Since there is no simple element to model a Warburg impedance, it isn't possible to construct a dummy cell that models the Randles Cell.

Figure 19
Randles Cell: Equivalent Circuit with Mixed Kinetic and Charge Transfer Control

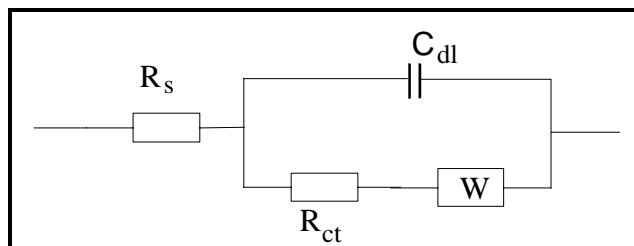

This circuit models a cell where polarization is due to a combination of kinetic and diffusion processes. The Nyquist Plot for this circuit is shown in Figure 20. As in the above example, the Warburg coefficient, σ , is assumed to be about 150. Other assumptions: $R_s = 20 \Omega$, $R_{ct} = 250 \Omega$ and $C_{dl} = 40 \mu\text{F}$.

Figure 20
Nyquist Diagram for Mixed Control Circuit

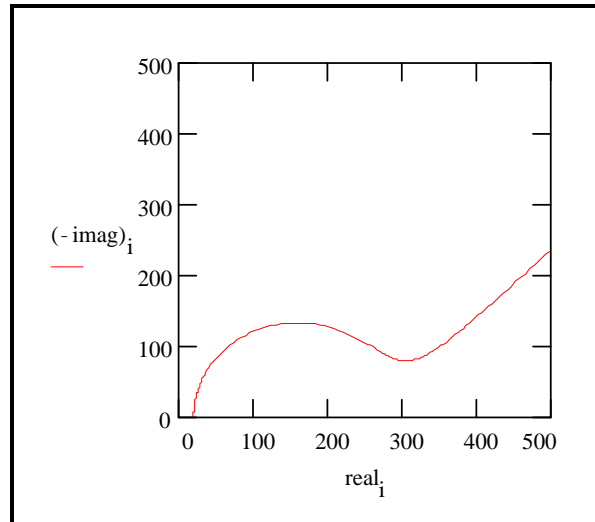

The Bode Plot for the same data is shown in Figure 21. The lower frequency limit was moved down to 1mHz to better illustrate the differences in the slope of the magnitude and in the phase between the capacitor and the Warburg impedance.

Figure 21
Bode Plot for the Mixed Control Circuit

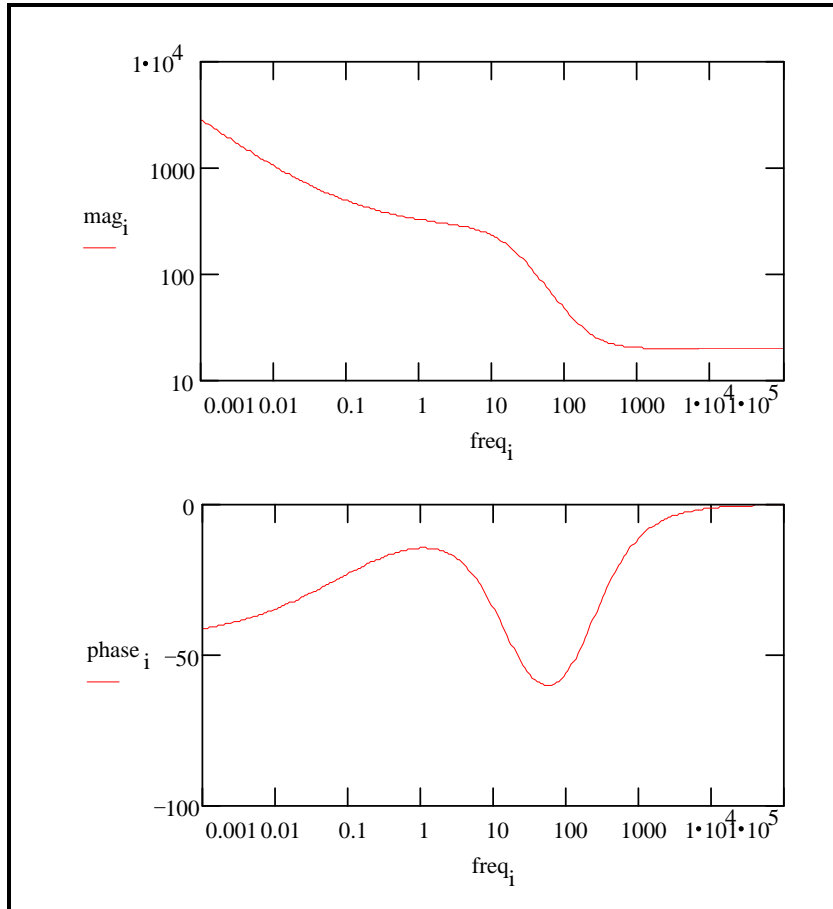

EIS of Coated Metals

The impedance behavior of a purely capacitive coating was discussed above. Most paint coatings degrade with time, resulting in more complex behavior.

After a certain amount of time, water penetrates into the coating and forms a new liquid/metal interface under the coating. Corrosion phenomena can occur at this new interface.

The impedance of coated metals has been very heavily studied. The interpretation of impedance data from failed coatings can be very complicated. Only the simple equivalent circuit shown in Figure 22 will be discussed here. Even this simple model has been the cause of some controversy in the literature. Researchers do not agree on the assignment of impedances to physical processes that can occur in the cell. The discussion below is therefore only one of several interpretations of this model.

Gamry scientists published three articles on the evaluation of organic coatings with EIS in JCT CoatingsTech (www.coatingstech.org). The articles are:

Fundamentals of Electrochemical Impedance Spectroscopy, August 2004.

Application of EIS to Coatings, October 2004.

Protocols for Testing Coatings with EIS, February 2005.

The capacitance of the intact coating is represented by C_c . Its value is much smaller than a typical double layer capacitance. Its units are pF or nF, not μF . R_{po} (pore resistance) is the resistance of ion conducting paths that develop in the coating. These paths may not be physical pores filled with electrolyte. On the metal side of the pore, we assume that an area of the coating has delaminated and a pocket filled with an electrolyte solution has formed. This electrolyte solution can be very different than the bulk solution outside of the coating. The interface between this pocket of solution and the bare metal is modeled as a double layer capacitance in parallel with a kinetically controlled charge transfer reaction.

Figure 22
Equivalent Circuit for a Failed Coating

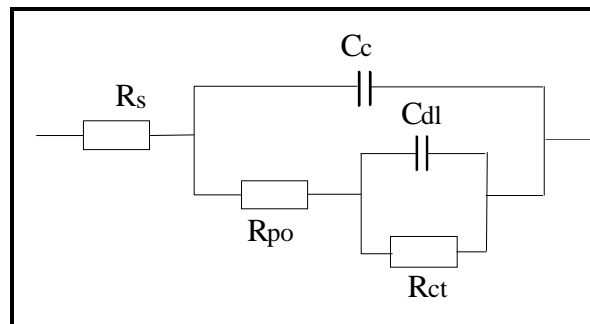

When you use EIS to test a coating, you fit a data curve to this type of model. The fit returns estimates for the model parameters, such as the pore resistance or the double layer capacitance. You then use these parameters to evaluate the degree to which the coating has failed.

In order to show realistic data curves, we need to do this operation in reverse. Assume that we have a 10 cm^2 sample of metal coated with a $12\text{ }\mu\text{m}$ film. Assume that we have 5 delaminated areas making up a total of 1% of the surface of the metal. The pores in the film that give access into these delaminated areas can be represented as being solution filled cylinders, with a $30\text{ }\mu\text{m}$ diameter.

The parameters used to develop the curves are shown below:

C_c	= 4 nF	Calculated for 10 cm^2 area, $\epsilon_r = 6$ and $12\text{ }\mu\text{m}$ thickness
R_{po}	= 3400 Ω	Calculated assuming k (conductivity) = 0.01 S/cm
R_s	= 20 Ω	Assumed
C_{dl}	= 4 μF	Calculated for 1% of 10 cm^2 area and assuming $40\text{ }\mu\text{F}/\text{cm}^2$.
R_{ct}	= 2500 Ω	Calculated for 1% of 10 cm^2 area and using Polarization Resistance assumptions from an earlier discussion.

With these parameters, the Nyquist Plot for this model is shown in Figure 23. Notice that there are two time constants in this plot.

Figure 23
Nyquist Plot for a Failed Coating

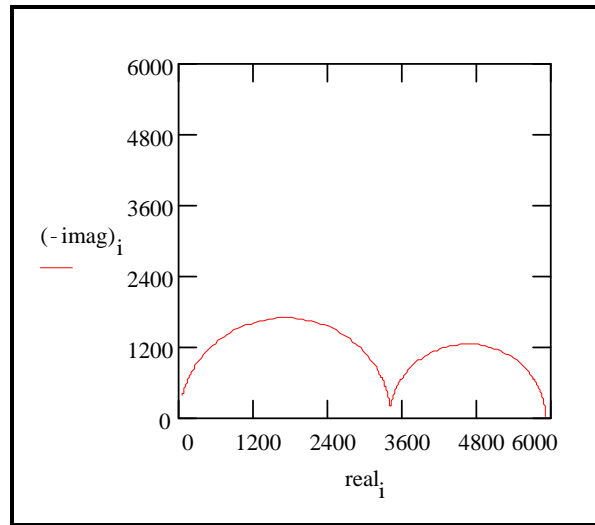

The Bode Plot of the same data is shown in Figure 24. The two time constants are not nearly as pronounced on this plot. The plot does not go sufficiently high in frequency to measure the solution resistance. In practice this is not a problem, because the solution resistance is a property of the test solution and the test cell geometry, not a property of the coating. It is, therefore, not very interesting.

Figure 24
Bode Plot for a Failed Coating

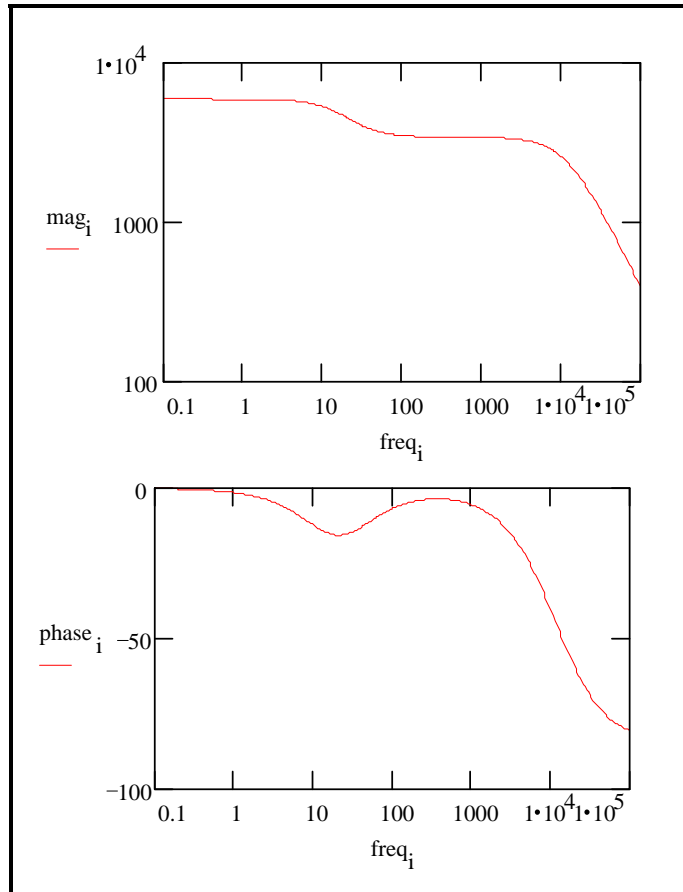

Extracting Model Parameters from Data

Modeling Overview

EIS data are generally analyzed in terms of an equivalent circuit model. The analyst tries to find a model whose impedance matches the measured data.

The type of electrical components in the model and their interconnections controls the shape of the model's impedance spectrum. The model's parameters (e.g., the resistance value of a resistor) control the size of each feature in the spectrum. Both these factors affect the degree to which the model's impedance spectrum matches a measured EIS spectrum.

In a physical model, each of the model's components is postulated to come from a physical process in the electrochemical cell. All of the models discussed earlier in this chapter are physical models. The choice of which physical model applies to a given cell is made from knowledge of the cell's physical characteristics. Experienced EIS analysts can also use the shape of a cell's EIS spectrum to help choose a model for that cell.

Models can also be partially or completely empirical. The circuit components in this type of model are not assigned to physical processes in the cell. The model is chosen to give the best possible match between the model's impedance and the measured impedance.

An empirical model can be constructed by successively subtracting component impedances from a spectrum. If the subtraction of an impedance simplifies the spectrum, the component is added to the model, and the next component impedance is subtracted from the simplified spectrum. This process ends when the spectrum is completely gone.

As we shall see below, physical models are generally preferable to empirical models.

Non-linear Least Squares Fitting

Modern EIS analysis uses a computer to find the model parameters that cause the best agreement between a model's impedance spectrum and a measured spectrum. A non-linear least squares fitting (NLLS) algorithm is used.

NLLS starts with initial estimates for all the model's parameters. Starting from this initial point, the algorithm makes a change in one of the parameter values and evaluates the resulting fit. If the change improves the fit, the new parameter value is accepted. If the change worsens the fit, the old parameter value is retained. Next a different parameter value is changed and the test is repeated. Each trial with new values is called an iteration. Iterations continue until the goodness of fit exceeds an acceptance criterion, or until the number of iterations reaches a limit.

NLLS algorithms are not perfect. In some cases they do not converge on a useful fit. This can be the result of several factors including:

- An incorrect model for the data set being fitted.
- Poor estimates for the initial values.
- Noise

In addition, the fit from an NLLS algorithm can look poor when the fit's spectrum is superimposed on the data spectrum. It appears as though the fit ignores a region in the data. To a certain extent this is what happens. The NLLS algorithm optimizes the fit over the entire spectrum. It does not care that the fit looks poor over a small section of the spectrum.

Multiple Models

The impedance spectrum in Figure 25 shows two clearly defined time constants.

Figure 25
Two Time Constant Spectrum

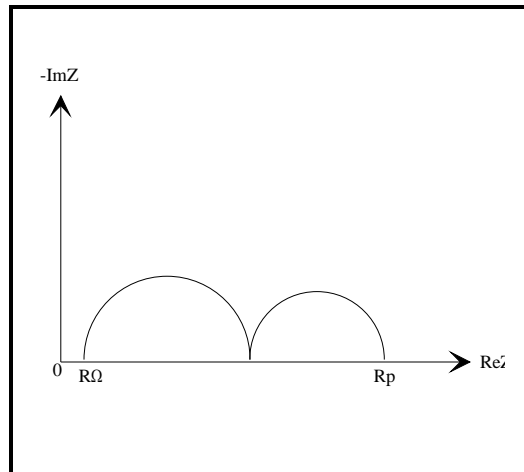

This spectrum can be modeled by any of the equivalent circuits shown in Figure 26.

Figure 26
Equivalent Circuit Models with Two Time Constants

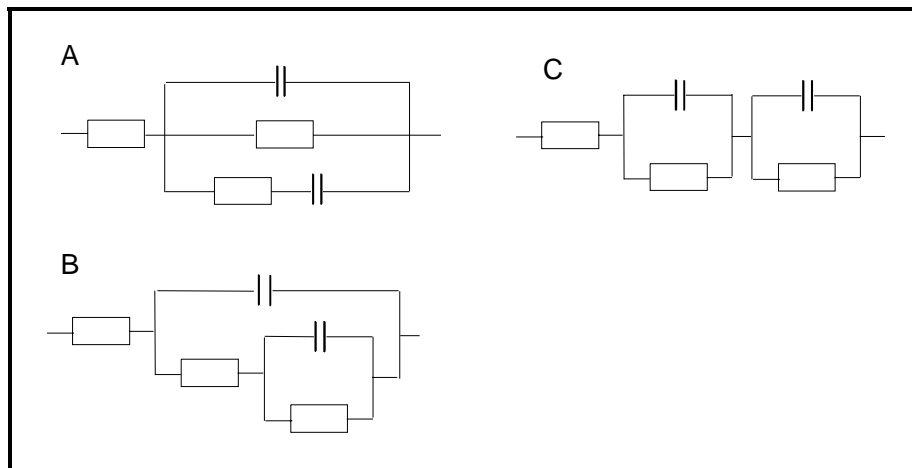

As you can see, there is not a unique equivalent circuit that describes the spectrum. Therefore, you can not assume that an equivalent circuit that produces a good fit to a data set represents an accurate physical model of the cell.

Even physical models are suspect in this regard. Whenever possible, the physical model should be verified before it is used. One way to verify the model is to alter a single cell component (for example increase a paint layer thickness) and see if you get the expected changes in the impedance spectrum.

Empirical models should be treated with even more caution. You can always get a good looking fit by adding additional circuit elements to a model. Unfortunately, these elements may have little relevance to the cell processes that you are trying to study. Empirical models should therefore use the fewest elements possible.

References

The following sources were used in preparing this Application Note. The reader is encouraged to consult them for additional information.

Evaluation of Organic Coatings with Electrochemical Impedance Spectroscopy. Part 1: Fundamentals of Electrochemical Impedance Spectroscopy. David Loveday, Pete Peterson, and Bob Rodgers, JCT CoatingsTech, 46-52, August 2004.

Evaluation of Organic Coatings with Electrochemical Impedance Spectroscopy. Part 2: Application of EIS to Coatings.. David Loveday, Pete Peterson, and Bob Rodgers, JCT CoatingsTech, 88-93, October 2004.

Evaluation of Organic Coatings with Electrochemical Impedance Spectroscopy. Part 3: Protocols for Testing Coatings with EIS. David Loveday, Pete Peterson, and Bob Rodgers, JCT CoatingsTech, 22-27, February 2005.

Electrochemical Impedance and Noise, Robert Cottis and Stephen Turgoose, NACE International, 1440 South Creek Drive, Houston, TX 77084, US, 1999. Website: www.nace.org.

Impedance Spectroscopy; Theory, Experiment, and Applications, 2nd ed. , E. Barsoukov, J.R. Macdonald, eds., Wiley Interscience Publications, 2005.

Electrochemical Methods; Fundamentals and Applications, A.J. Bard, L.R. Faulkner, Wiley Interscience Publications 2000.

Electrochemical Impedance: Analysis and Interpretation, J.R. Scully, D.C. Silverman, and M.W. Kendig, editors, ASTM, 1993.

Physical Chemistry, P.W. Atkins, Oxford University Press 1990.

Signals and Systems, A.V. Oppenheim and A.S. Willsky, Prentice-Hall, 1983.

The Use of Impedance Measurements in Corrosion Research; The Corrosion Behaviour of Chromium and Iron Chromium Alloys, J.A.L. Dobbelaar, Ph-D thesis TU-Delft 1990.

Characterization of Organic Coatings with Impedance Measurements; A study of Coating Structure, Adhesion and Underfilm Corrosion, F. Geenen, Ph-D thesis, TU-Delft 1990.

Identification of Electrochemical Processes by Frequency Response Analysis, C. Gabrielle, Solartron Instrumentation Group 1980.

Comprehensive Treatise of Electrochemistry; Volume 9 Electrodeics: Experimental Techniques; E. Yeager, J.O'M. Bockris, B.E. Conway, S. Sarangapani, chapter 4 "AC Techniques", M. Sluyters-Rehbach, J.H. Sluyters, Plenum Press 1984.

Mansfeld, F., "Electrochemical Impedance Spectroscopy (EIS) as a new tool for investigation methods of corrosion protection", *Electrochimica Acta*, **35** (1990) 1533.

Walter, G.W., "A review of impedance plot methods used for corrosion performance analysis of painted metals", *Corrosion Science*, **26** (1986) 681.

Kendig, M., J. Scully, "Basic aspects of electrochemical impedance application for the life prediction of organic coatings on metals", *Corrosion*, **46** (1990) 22.

Fletcher, S., "Tables of Degenerate Electrical Networks for Use in the Equivalent-Circuit Analysis of Electrochemical Systems", *J. Electrochem. Soc.*, **141** (1994) 1823.

©Gamry Instruments Copyright 2006 Rev. 3

